



KBPC-240D (Part Nos. 9338 and 9342) Installation and Operation Manual Supplement

This supplement is for Model KBPC-240D Installation and Operation Manual (Part No. A40400) until the new manual is available. The manual must be read and understood before operating this drive. For further assistance, contact our Sales Department at 954-346-4900 or Toll Free at 800-221-6570 (outside Florida).

PRODUCT UPDATES

- Run Relay Added
- SMT Construction

This drive has been converted to Surface Mount Technology (SMT). All trimpots have been moved and aligned at the top of the PC board. A Run Relay has been added, which can be used to turn equipment "on" or "off" as a function of drive status (Off, Stop, Run). The General Performance Specifications, Electrical Ratings, Mechanical Specifications, and Connection Diagrams have not changed. The Parts List (Table 11, on pages 17 and 18) and Schematic (Figure 16, on page 19) in the manual no longer apply to this drive and should not be used. See Figure 1 for the location of the Run Relay Output Contacts, Trimpots, and Jumpers (replaces Figure 1, on page 3, in the manual). See Figure 1 for the Run Relay Output Contacts ratings. See Table 1 for the drive operating conditions and Run Relay Output Contacts status.

FIGURE 1 - DRIVE LAYOUT

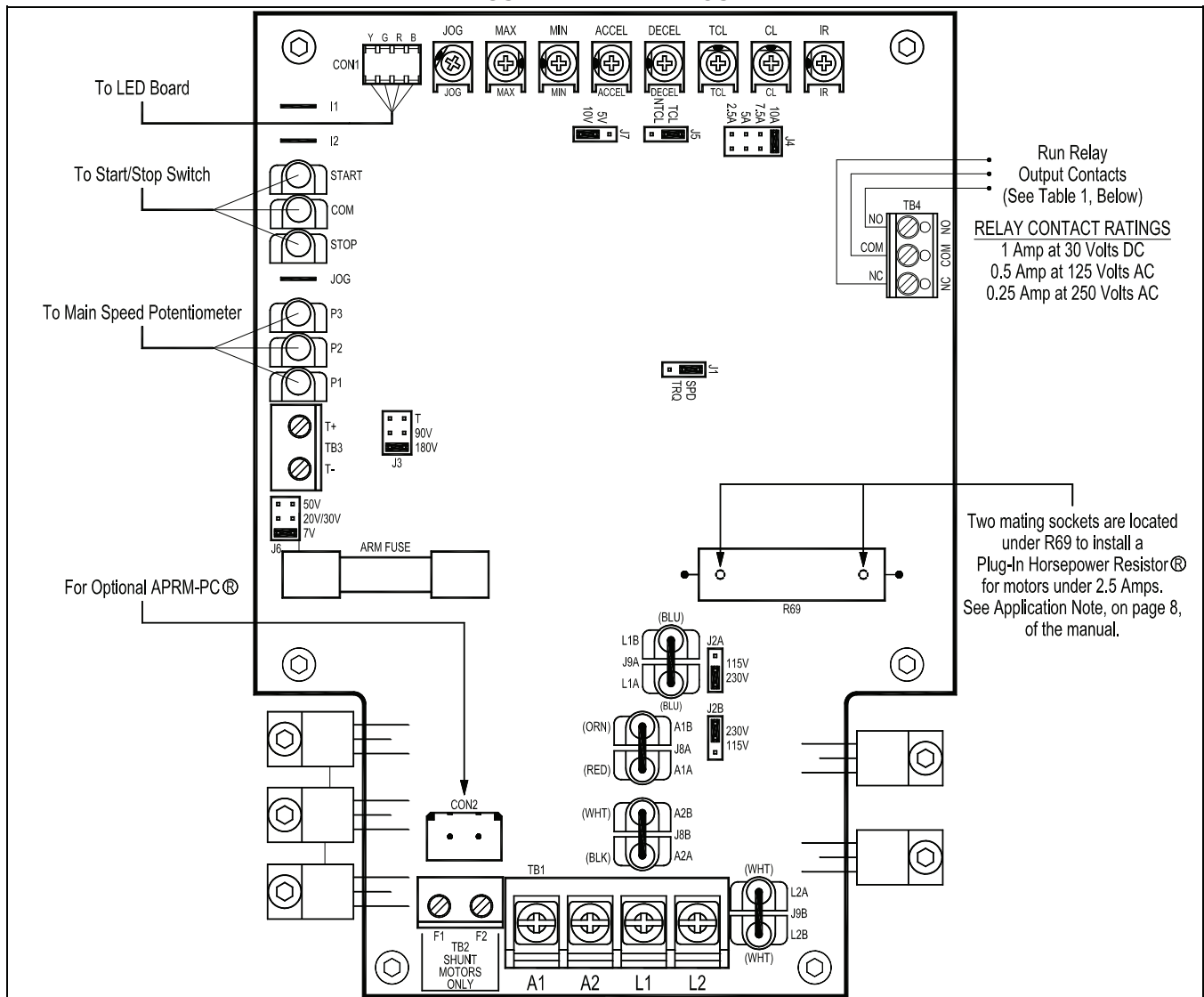

TABLE 1 - DRIVE OPERATING CONDITION AND RUN RELAY OUTPUT CONTACTS STATUS

Drive Operating Condition	Description	Normally Open Contact	Normally Closed Contact
Power Off	Main Power Disconnected	Open	Closed
Run Mode	Normal Drive Operation	Closed	Open
Stop Mode	Selected by Operator	Open	Closed
Trip	Drive Tripped	Open	Closed

INSTALLATION AND OPERATING INSTRUCTIONS

MODEL KBPC-240D

KB Part No. 9338 (Black Case) • Part No. 9342 (White Case)

NEMA 4X, IP-65

SCR Speed and Torque Control Designed
For DC Motors Rated
1/50 – 1 HP @ 90VDC, 1/25 – 2 HP @ 180VDC

This control will not operate without installing the correct armature fuse – supplied separately.

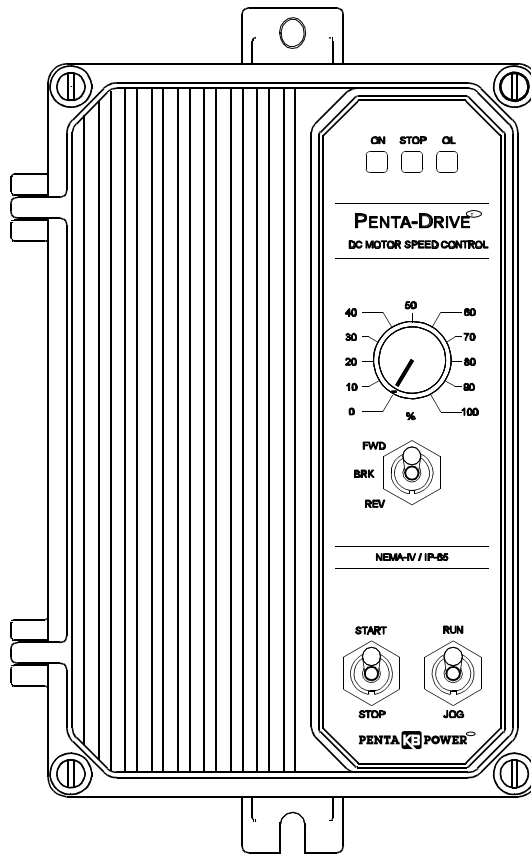

Note: Product illustration is shown with optional Forward-Brake-Reverse and Run-Jog options.



See Safety Warning on Page 2

The information contained in this manual is intended to be accurate. However, the manufacturer retains the right to make changes in design which may not be included herein.

PENTA KB POWER™

A COMPLETE LINE OF MOTOR DRIVES

TABLE OF CONTENTS

<u>Section</u>	<u>Page</u>
i. KBPC-240D Simplified Operating Instructions	1
ii. Safety Warning	2
I. General Information	2
II. Setting Selectable Jumpers	5
III. Mounting	9
IV. Wiring	10
V. Fusing	13
VI. Operation	13
VII. Trimpot Adjustments	14
VIII. Function Indicator Lamps	15
IX. Optional Accessories	15
X. Limited Warranty	22

TABLES

1. Electrical Ratings	5
2. General Performance Specifications	5
3. Setting AC Line Voltage with Jumper J2A and J2B	7
4. Setting Armature Voltage with Jumper J3	8
5. Jumper J4 vs Motor Horsepower	8
6. Current Limit Settings with .05 Ohm Plug-In-Horsepower Resistor Installed	8
7. Terminal Block Wiring Information	10
8. Relationship of AC Line Input and Motor Voltage with J2 and J3 Jumper Position	10
9. Field Connections (Shunt Wound Motors Only)	11
10. Armature Fuse Chart	13
11. Parts List	17, 18

FIGURES

1. Control Layout	3
2. Mechanical Specifications	4
3. Motor Speed vs Potentiometer Rotation	6
4. Preset Motor Speed vs Motor Load	6
5. Motor Output Torque vs Potentiometer Rotation	7
6. Motor Speed vs Applied Motor Load	7
7A. Captive Screw Tightened in Case	10
7B. Captive Screw Engaged in Front Cover	10
8. Connection Diagram	10
9A. Full Voltage Field	11
9B. Half Voltage Field	11
10. Tach-generator Connection Diagram	11
11. Remote Potentiometer	12
12. Analog Voltage	12
13. Remote Start/Stop Switch	12
14. Inhibit Circuit	12
15. Enable Circuit	13
16. Schematic	19
17. Connection Diagram for KBPC-240D with KBSI-240D Signal Isolator	20
18. Internal Connection Diagram	21
19. Connection Diagrams for Available Options	21

i.   **KBPC-240D SIMPLIFIED OPERATING INSTRUCTIONS**

IMPORTANT – You must read these simplified operating instructions before you proceed. These instructions are to be used as a reference only and are not intended to replace the detailed instructions provided herein. You must read the Safety Warning on page 2 before proceeding.

1. CONNECTIONS.

A. AC Line – Wire AC line voltage to terminals L1 and L2. Be sure jumpers J2A and J2B are both set to the correct input line voltage 115 or 230 VAC. Connect ground wire (earth) to green ground screw on case.

B. Motor.

1. Permanent Magnet (PM) Type. Connect motor armature leads to A1(+) and A2(–). Be sure jumper J3 is set to the proper position “90V” for 90 volt DC motors and “180V” for 180 volt DC motors. Note: 180 volt DC motors must be used with 230 VAC line, 90 volt motors can be used with a 230 VAC or 115 VAC line. See sec. II, C, on page 7.
2. Shunt Wound Motors. Connect motor armature as above. Connect full voltage shunt field wires (90 volt motors with 100 volt fields and 180 volt motors with 200 volt fields) to F1 and F2. Connect half voltage field wires (90 volt motors with 50 volt fields and 180 volt motors with 100 volt fields) to F1 and L1. See sec. IV, C, on page 11.

2. SPEED OR TORQUE MODE.

Jumper J1 is factory set for speed control operation (SPD). For torque control, set J1 to TRQ position. See sec. II, A, on page 5.

3. MOTOR CURRENT.

Jumper J4 is factory set for 10 amp motors (10A). For lower amperage motors, place J4 in the proper position. See section II, D, on page 8 for details. Note: The factory setting for Current Limit is 150% of the nominal current setting, e.g., if J4 is selected for 10 amps, the actual CL setting will be 15 amps.

4. TRIMPOT SETTINGS.

All trimpots have been factory set in accordance with figure 1, page 3 and table 1, page 5.

5. DIAGNOSTIC LED's.

After power is turned on, observe LED's to verify proper control function. See sec. VIII on page 15.

6. ARMATURE FUSE.

The correct size armature fuse **must be installed**, depending on the rating of the motor. Control will not operate if fuse is not installed. See section V, B on page 13 and table 6 on page 12.

7. START/STOP SWITCH.

The KBPC contains a built-in manual start/stop switch. This switch must be used to start the control each time AC power is lost. To override this function see sec IV, G, p. 12.



ii. SAFETY WARNING! — PLEASE READ CAREFULLY

This product should be installed and serviced by a qualified technician, electrician or electrical maintenance person familiar with its operation and the hazards involved. Proper installation, which includes wiring, mounting in proper enclosure, fusing or other overcurrent protection and grounding, can reduce the chance of electric shocks, fires or explosion in this product or products used with this product, such as electric motors, switches, coils, solenoids and/or relays. Eye protection must be worn and insulated adjustment tools must be used when working with control under power. This product is constructed of materials (plastics, metals, carbon, silicon, etc.) which may be a potential hazard. Proper shielding, grounding and filtering of this product can reduce the emission of radio frequency interference (RFI) which may adversely affect sensitive electronic equipment. If information is required on this product, contact our factory. It is the responsibility of the equipment manufacturer and individual installer to supply this safety warning to the ultimate user of this product. (SW effective 11/92)

This control contains electronic Start/Stop and inhibit circuits that can be used to start and stop the control. However, these circuits are never to be used as safety disconnects since they are not fail-safe. Use only the AC line for this purpose.

The input circuits of this control (potentiometer, start/stop, Inhibit) are not isolated from AC line. **Be sure to follow all instructions carefully. Fire and/or electrocution can result due to improper use of this product.**



This product complies with all CE directives pertinent at the time of manufacture. Contact factory for detailed installation instructions and Declaration of Conformity. Installation of a CE approved RFI filter (KBRF-200A, KB P/N 9945A or equivalent) is required. Additional shielded motor cable and/or AC line cables may be required along with a signal isolator (KBSI-240D, KB P/N 9431 or equivalent).

I. GENERAL INFORMATION.

The KBPC Series Nema 4 X (IP-65) is a unidirectional SCR DC Motor Speed and Torque Control designed for applications requiring watertight integrity, including washdown. Its housing is ruggedly constructed of die cast aluminum, protected with an acrylic coating that provides excellent corrosion resistance. All switches are sealed with rubber boots and the main speed potentiometer contains a shaft seal.

The electronics for the KBPC is state-of-the-art and includes short circuit and transient protection which provides the ultimate in reliability. Electronic overload protection prevents motor burnout and demagnetization of PM motors. The control can be operated in either the Speed or Torque mode via jumper selection. The current range, which is also jumper selectable, eliminates the necessity for calibration of IR Compensation and Current Limit for most applications. The KBPC also contains jumper selections for AC line voltage (230/115), DC armature voltage (180/90) and feedback type (armature/Tach-generator).

Standard features include armature fusing*, electronic start/stop and an LED indicator array for Power On, Stop and Overload (*fuse supplied separately).

Although the KBPC is factory set for most applications, a variety of trimpots allow adjustment of the following parameters: Minimum and Maximum Speed, Acceleration, Deceleration, Current Limit, IR Comp, and Timed Current Limit. Optional features offered are: On/Off AC Line Switch, Forward-Brake-Reverse, Run-Stop-Jog, Input Signal Isolation, RFI Filtering, and Electronic Run-Brake Module.



WARNING! Be sure to follow all instructions carefully. Fire or electrocution can result due to improper use of this product. Read Safety Warning.

FIG. 1 – CONTROL LAYOUT

(Illustrates Factory Setting of Jumpers and Approximate Trimpot Settings)

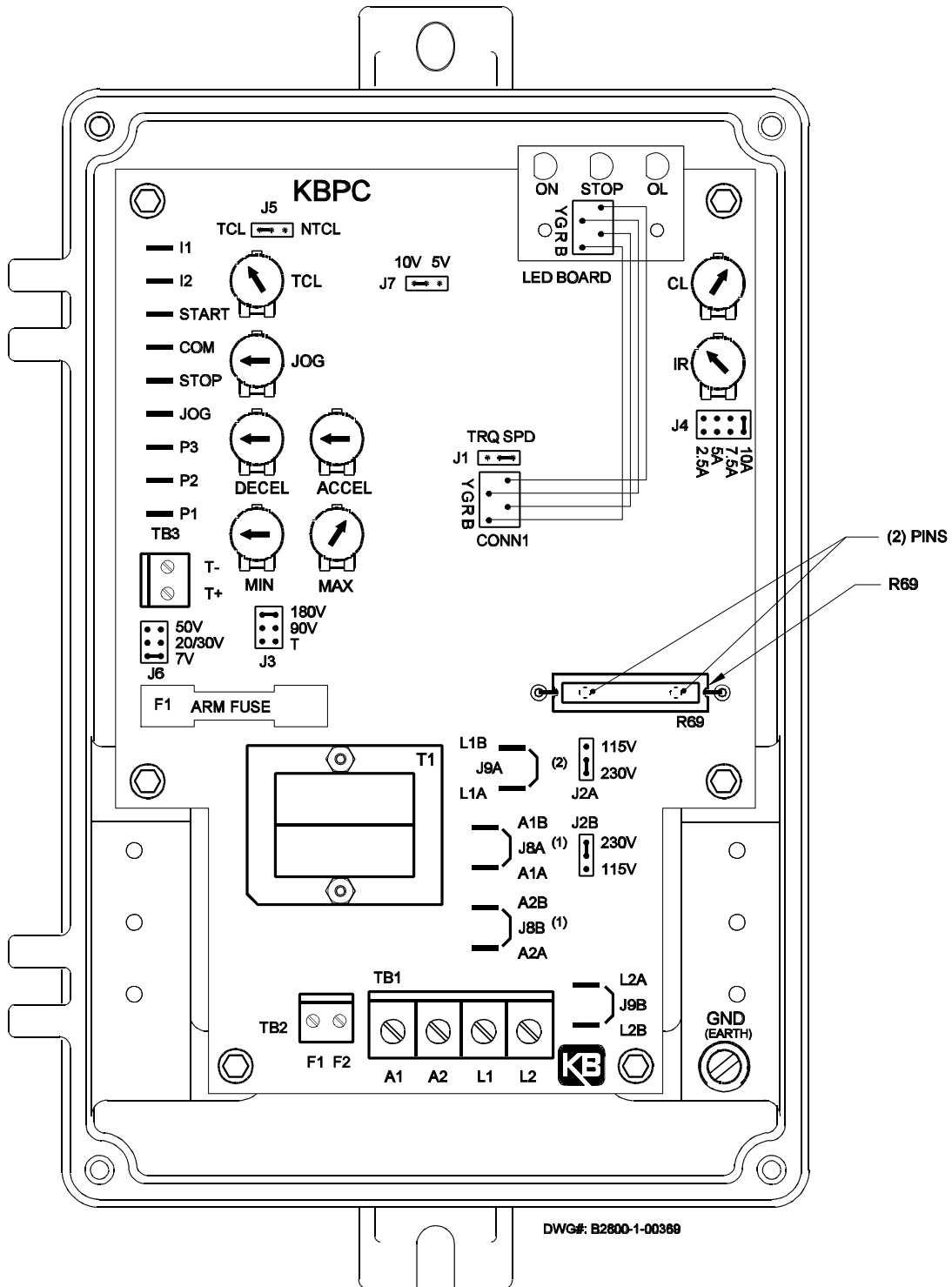

INCHES
[mm]

FIG. 2 – MECHANICAL SPECIFICATIONS

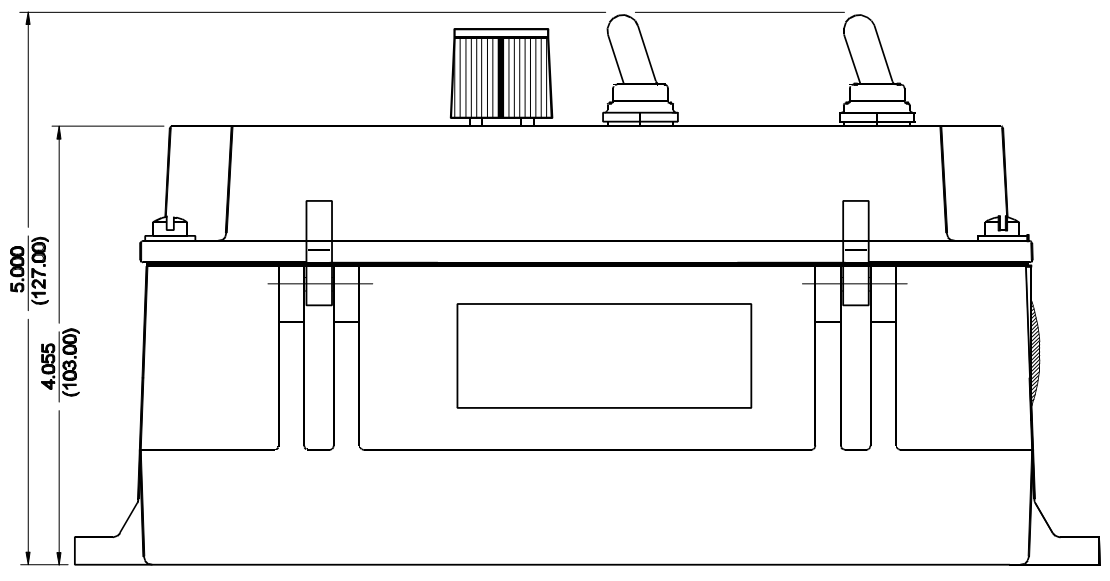
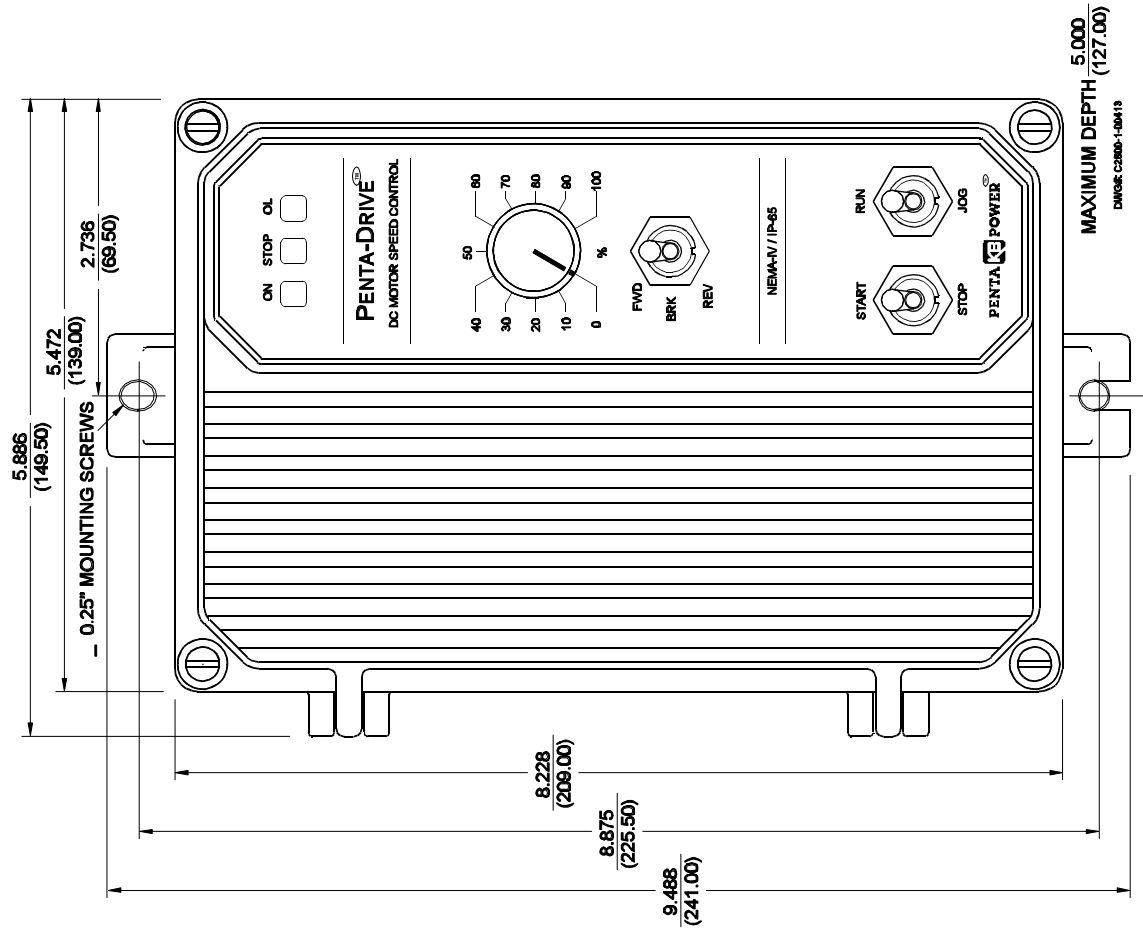

TABLE 1 – ELECTRICAL RATINGS

Model	Input Voltage (VAC)	Max. AC Current (ARMS)	Output Voltage (VDC)	Max. DC Output Current (ADC)	Max. HP, (KW)
KBPC-240D	115	15.0	0 – 90	10.2	1, (.75)
	230	15.0	0 – 180	10.2	2, (1.5)
	230	15.0	0 – 90	10.2	1, (.75)

TABLE 2 – GENERAL PERFORMANCE SPECIFICATIONS

Parameter	Specification	Factory Setting
AC Line Input Voltage (VAC \pm 10%,50/60 Hz)	115 or 230	230
AC Line Frequency (Hz), # of Phases	50/60, 1	—
Arm Voltage Range at 115VAC Line (VDC)	0 – 90	—
Arm Voltage Range at 230VAC Line (VDC)	0 – 180, 0 – 90	0 – 180
Field Voltage at 115VAC Line (VDC)	100/50	—
Field Voltage at 230VAC Line (VDC)	200/100	—
Horsepower Range at 115 VAC HP, (KW)	1/50 – 1, (.015 – .75)	—
Horsepower Range at 230 VAC HP, (KW)	1/25 – 2, (.03 – 1.5)	—
Ambient Temperature Range (°C)	0 – 50	—
Speed Range (Ratio)	50:1	—
Arm Feedback Load Regulation (% Base Speed)	\pm 1	—
Tach Feedback Load Regulation (% Set Speed)	\pm 1	—
Line Regulation (% Base Speed)	\pm 0.5	—
Current Ranges (ADC)	2.5, 5.0, 7.5, 10	10
ACCEL and DECEL Ranges (Sec.)	0.1 – 15	1
MIN Speed Range (% Base Speed)	0 – 30	0
MAX Speed Range (% Base Speed)	60 – 140	100
IR Comp Range at 115VAC Line (VDC)	0 – 15	4
IR Comp Range at 230VAC Line (VDC)	0 – 30	8
CL Range (% Range Setting)	0 – 200	150
Timed CL Range (Sec.)	0.5 – 15	7
Voltage Following Linearity (% Base Speed)	\pm 0.5	—

II. SETTING SELECTABLE JUMPERS.

The KBPC-240D has customer selectable jumpers which must be set before the control can be used. Bold indicates factory setting. See fig. 1, page 3 for location of jumpers.

A. Control Mode – Speed (SPD) or Torque (TRQ). Note: Factory setting for J1 is Speed mode. When Jumper J1 is placed in the "SPD" position the drive will control motor speed as a linear function of the main potentiometer rotation, or analog voltage input. The range of output speed can be adjusted with the MIN and MAX trimpots. The motor will maintain the preset speed as long as the maximum load does not exceed the current limit set point. If the motor load exceeds the current limit setting, the Overload LED will turn on and the motor will stall.



FIG. 3 – MOTOR SPEED vs POTENTIOMETER ROTATION – [SPEED MODE]

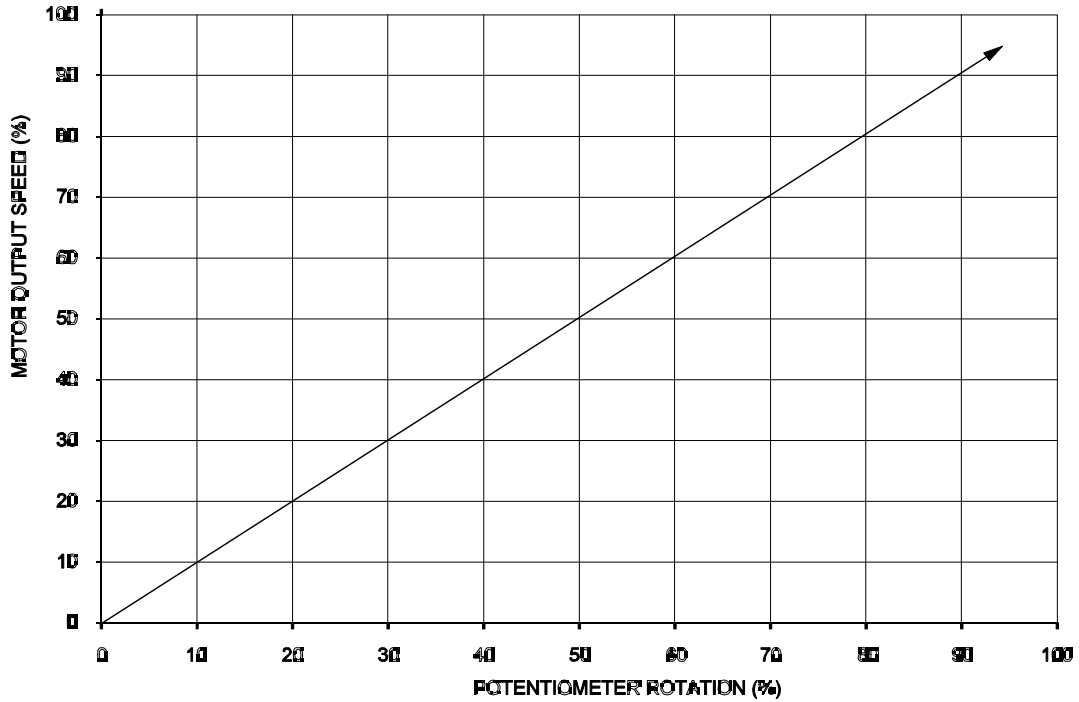
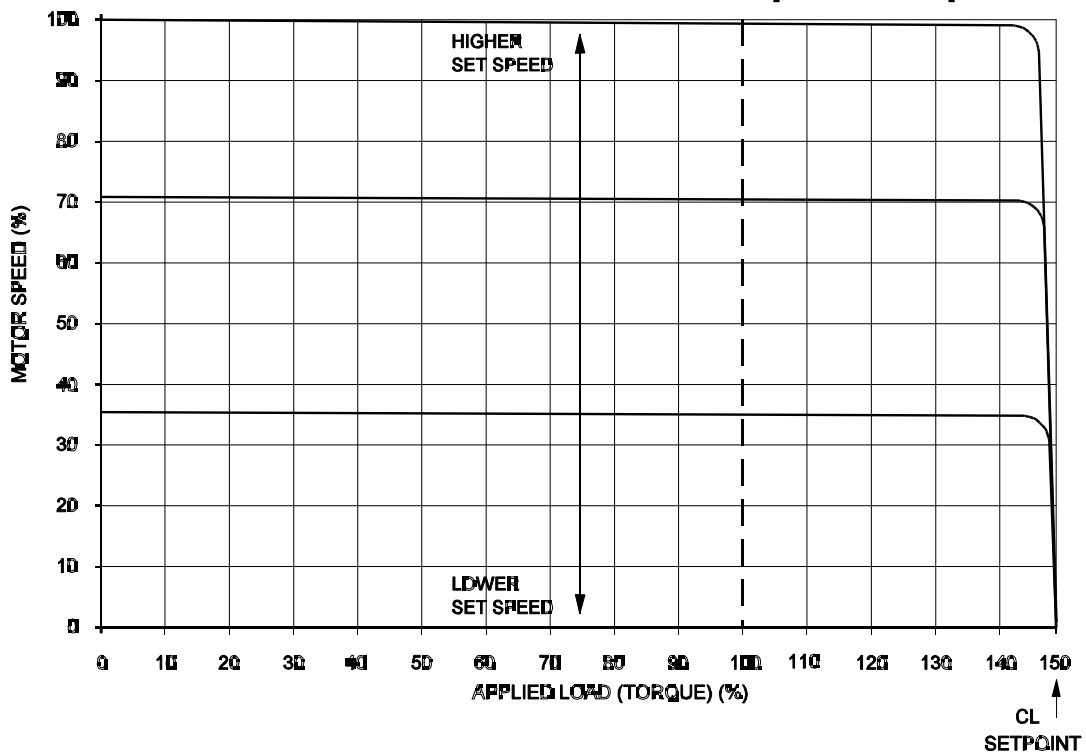

FIG. 4 – PRESET MOTOR SPEED vs MOTOR LOAD – [SPEED MODE]



When Jumper J1 is placed in the "TRQ" position, the drive will control motor torque as a linear function of main potentiometer rotation. If the motor load exceeds the torque setting, the motor will stall, the Overload LED will light, and the drive will apply a constant preset torque based on the potentiometer setting. The Overload LED will light when the load torque approaches the current limit set point. The torque limits are set via jumper J4 and the CL trimpot. (Note: When operating in the Torque Mode, Jumper J5 **must** be in the "NTCL" position or drive will shut down when CL Timer times out.)

FIG. 5 – MOTOR OUTPUT TORQUE vs POTENTIOMETER ROTATION – [TORQUE MODE]

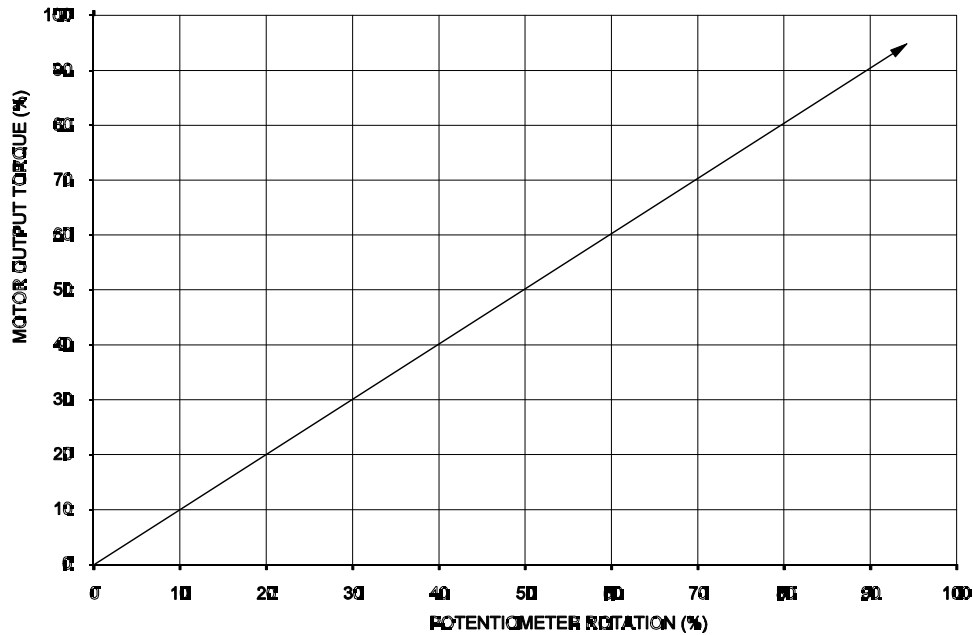
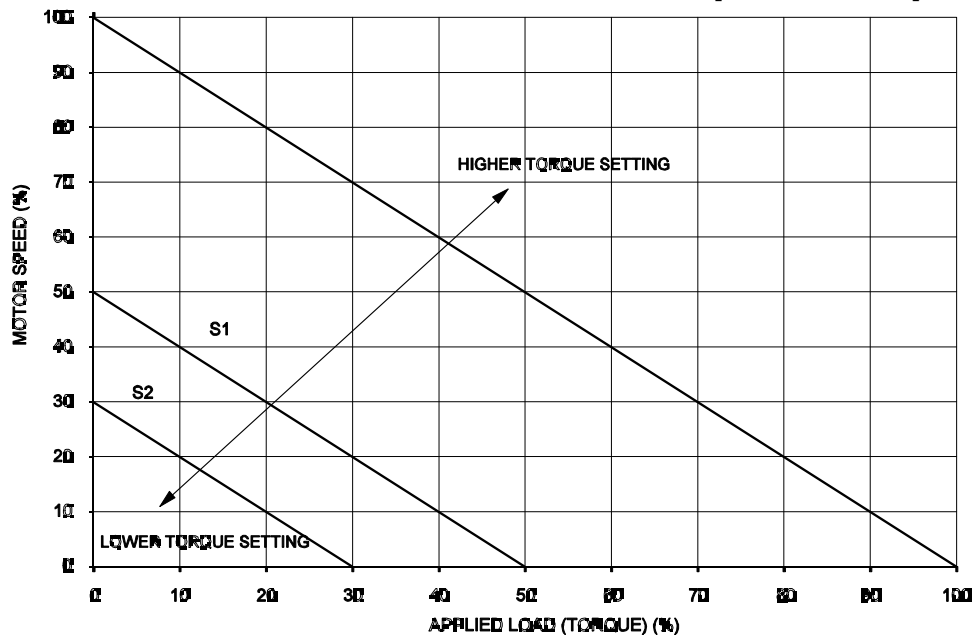

FIG. 6 – MOTOR SPEED vs APPLIED MOTOR LOAD – [TORQUE MODE]







B. J2A, J2B – Input AC Line Voltage –

Select proper input line voltage 115VAC or 230VAC by placing **both** J2A and J2B in the correct corresponding positions, "115V" or "230V."

C. J3 – Armature Voltage Output and Tach-generator Feedback –



Select the desired armature voltage by placing J3 in the proper position "90V" for 90 – 130VDC motors and "180V" for 180 – 220 VDC motors. For 115VAC line input the armature voltage must be set to "90V."

TABLE 3 – SETTING AC LINE VOLTAGE WITH JUMPER J2A and J2B

Control Set for 230 VAC (Factory Setting)	Control Set for 115 VAC
 J2A	 J2A
 J2B	 J2B

For 230VAC line input, the armature voltage is normally set to "180V". However, it is also possible to operate in a Step-Down Mode (90 – 130VDC motor with a 230VAC line) by setting J3 to "90". However, reduced performance may result.

TABLE 4 – SETTING ARMATURE VOLTAGE WITH JUMPER J3

Control Set for 180 VDC (Factory Setting)	Control Set for 90 VDC
 <p>J3</p>	 <p>J3</p>

If tach-generator feedback is to be used, J3 must be placed in the "T" position and an external DC tach-generator must be connected. See section II, F, p. 9, and section IV, E on page 11 for additional information.

- D. J4 – Armature Current** – Select the J4 position (2.5A, 5A, 7.5A, **10A**) closest to the rated motor current. Note that the output is factory set to 150% of the J4 position (e.g. 15 amps in the 10A position and 11 amps in the 7.5 position, etc.). This setting can be readjusted using the CL trimpot (see section VII, E on page 14).

TABLE 5 – JUMPER J4 SETTING vs MOTOR HORSEPOWER

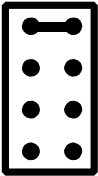
JUMPER J4*		Motor Horsepower Range	
		90 VDC	180 VDC
10.0 Amps		1	2
7.5 Amps		3/4	1
5.0 Amps		1/3 – 1/2	3/4 – 1
2.5 Amps		1/6 – 1/4	1/3 – 1/2

Note: Jumper J4 is shown in the factory setting.

Application Note – Subfractional Horsepower Motors. For subfractional motors with current ratings below 2.5 amps, the KBPC can be modified as follows. Note: Before making this modification you must have a .05 ohm Plug-in Horsepower Resistor® (KB P/N 9839). Carefully clip out the large power resistor R69 on the printed circuit board. The resistor location is indicated in fig. 1, p. 3.) Insert the .05 ohm Plug-in Horsepower Resistor® into the two (2) pins located under the resistor R69. Each of the current selection values are now divided by 10. See table 6 below.

TABLE 6 – CURRENT LIMIT SETTINGS with .05 OHM PLUG-IN HORSEPOWER RESISTOR INSTALLED

Original J4 Current Jumper Selection	New J4 Current Jumper Selection	New Current Limit Trimpot Range	New Current Limit Trimpot Factory Setting
10.0 Amps	1.0 Amps	0 – 2.0 Amps	1.50 Amps
7.5 Amps	0.75 Amps	0 – 1.5 Amps	1.13 Amps
5.0 Amps	0.5 Amps	0 – 1.0 Amps	0.75 Amps
2.5 Amps	0.25 Amps	0 – 0.5 Amps	0.38 Amps

- E. J5 – Current Limit Mode** – (Factory set for "TCL") This control contains electronic current limiting which limits the maximum DC current to the motor (the current limit set point is established with the selection of the J4 position and the setting of the CL trimpot). Two modes of current limit operation are provided:

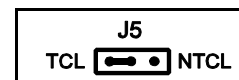

1. Timed current limit "TCL": In this mode the drive will turn off after being in current limit for a preset time. The time period is adjustable with the TCL trimpot from 0.5-15 seconds and is factory set for approximately seven (7) seconds. **TCL provides electronic motor overload protection.**

Application Note: After the control times out in TCL, it can be reset using the Start Switch by setting the switch to the "STOP" position and then to "START," or by disconnecting and reconnecting the AC line. If the Start Switch is jumpered out, the control can be restarted after timing out in TCL, by disconnecting and reconnecting the AC line. Note, the Overload lamp will remain lighted until the control is reset.

2. Non-Timed Current Limit "NTCL": In this mode the drive will reach the preset current limit during overload and stay at that level until a fuse blows or the drive is manually turned off. If non-timed CL operation is desired, move jumper J5 from the factory set "TCL" position to the "NTCL" position. The NTCL position must be used when operating in the Torque Mode. See section II, A on page 5.

F. J6 – Tach-generator voltage – (Note: Selection of this jumper position is not required if tach-generator feedback is not used.) If tach-generator feedback is used, select the J6 position (7V, 20/30V, 50V) which corresponds to the tach-generator voltage in **Volts/1000 RPM**. The selection of J6 position is based on a maximum motor speed of 1800 RPM. If other than standard tach-generator voltages and motor speeds are used, an external resistor (RT) may be used (1/2 watt rating).

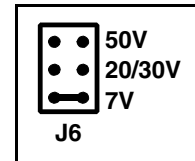

1. Install resistor (RT) in series with either tach-generator lead.
2. Place J6 in "7V" position.
3. Calculate the value of (RT) as follows:

$$RT = [(1.64 \times VT \times S) - 20,000] \text{ ohms} \quad \begin{cases} VT = \text{Tach Voltage in Volts/1000 RPM} \\ S = \text{Base speed of motor in RPM} \end{cases}$$

Note: For tach-generator feedback, Jumper J3 must be in the "T" position.

G. J7 – Signal Input Voltage – The output of this control is normally controlled with the main potentiometer. However, an **Isolated** analog voltage may also be used in place of a potentiometer. The control can be scaled for either a 0-5VDC or 0-10VDC by placing J7 in the appropriate position "5V" or "**10V**". The scaling can be further adjusted with the "Max" trimpot. See section IV, F 2, on page 12 for wiring information.

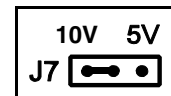

Note: If an **Isolated** input signal is not available an accessory Signal Isolator Model KBSI-240D (KB P/N-9431) can be installed. The KBSI-240D accepts a wide range of signal voltage and current. An Installation Kit containing Auto/Man Switch and required wiring is also available (P/N 9377).

III. MOUNTING

Mount the control in a vertical position on a flat surface. Be sure to leave enough room below the bottom of the control to allow for the AC line and motor connections. Although the control is designed for outdoor and washdown use, care should be taken to avoid extremely hazardous locations where physical damage can occur. **Note: Do not use this control in an explosion proof application.** If the control is mounted in a closed, unventilated cabinet, remember to allow for proper heat dissipation. If full rating is required, a minimum enclosure size of 12" W x 24" H x 12" D should be used.

Front Cover - The KBPC case is designed with a hinge so that when the front cover is open, all wiring stays intact. To open the cover, the four cover screws must be loosened, so they no longer are engaged in the case bottom. Note that these screws are captive and the front cover holes are threaded. After mounting and wiring, close the front cover, making sure all wires are contained within the enclosure and the gasket is in place around the cover lip. Tighten all four cover screws so that the gasket is slightly compressed. **Do not overtighten.**

FIG. 7A – CAPTIVE SCREW TIGHTENED IN CASE

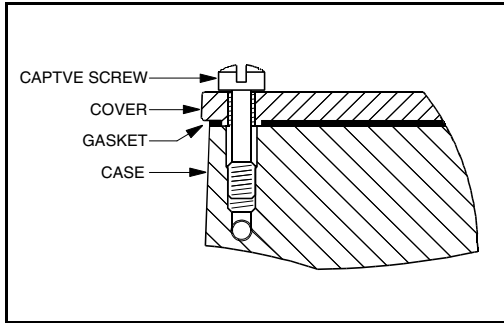
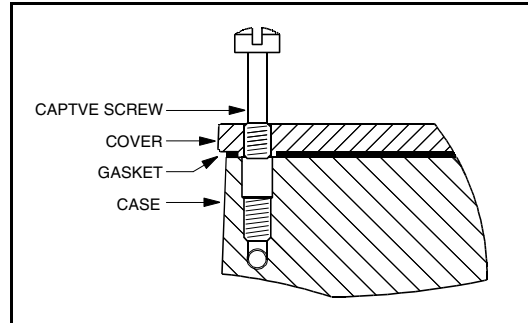

FIG. 7B – CAPTIVE SCREW ENGAGED IN FRONT COVER



IV. WIRING.  **Warning! Read Safety Warning before attempting to use this control.**

Warning! To avoid erratic operation do not bundle AC Line and motor wires with potentiometer, voltage following, enable, inhibit or other signal wiring. Use shielded cables on all signal wiring over 12" (30 cm) – Do not ground shield.

Wire control in accordance with the National Electric Code requirements, and other codes that apply. Be sure to fuse each conductor which is not at ground potential. **Do not fuse neutral or grounded conductors.** Note: See section V, Fusing, on page 13. A separate AC line switch, or contactor, must be wired as a disconnect switch, so that the contacts open each ungrounded conductor. An accessory ON/OFF AC Line Switch (KB P/N 9341) may be installed in this control in lieu of, or in addition to, the Start/Stop Switch normally provided. The switch can be wired for double pole or single pole operation. (See fig. 8, for AC Line and Armature connection.)

To maintain the watertight integrity of the control, be sure to use suitable watertight connectors and wiring, which are appropriate for the application. Two .875" (22.2 mm) knockout holes are provided for a standard 1/2" knockout connector (not supplied) for wiring. A watertight plug is provided if only one knockout is required.

- A. AC Line** – Connect AC Line to terminals L1 and L2. (Be sure jumpers J2A and J2B are set to the correct position to match the AC line input voltage. See table 8 on page 11.

TABLE 7 – TERMINAL BLOCK WIRING INFORMATION

Terminal Block Designation	Connection Designation	Supply Wire Gauge*		Maximum Tightening Torque (lbs inch)
		Minimum	Maximum	
TB1	A1, A2, L1, L2	22	12	12
TB2	F1, F2	22	14	3.5
TB3	T+, T-	22	14	3.5

*Use Cu wire only (AWG)

- B. Motor Armature** – Connect motor armature to terminals A1 (+) and A2 (-). (Be sure jumper J3 is set to closely match motor voltage. See table 8, p. 11.) **WARNING!** Do not wire switches or relays in series with the armature. **Armature switching can cause catastrophic failure of motor and/or control. Do not bundle AC and motor wires with other wires (e.g., potentiometer, analog input, Forward-Brake-Reverse, etc.).**

FIG. 8 – CONNECTION DIAGRAM

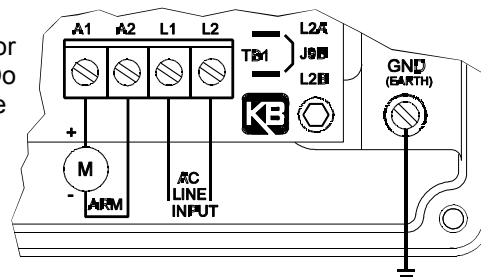

TABLE 8 – RELATIONSHIP of AC LINE INPUT AND MOTOR VOLTAGE with J2 and J3 JUMPER POSITION

AC INPUT VOLTAGE	J2A, J2B POSITION	J4 POSITION	MOTOR VOLTAGE
115	115	90	90
230	230	180	180
230	230	90*	90*

*A 90VDC motor can be used with a 230VAC line. However, speed range may be reduced and motor derating may be required.

C. Field – For Shunt Wound Motors Only. Do not use terminals F1 and F2 for any other purpose than to power the field on a shunt wound motor. Connect motor shunt field to terminals F1 and F2 for 90VDC motors with 100VDC fields and 180VDC motors with 200VDC fields. For motors with half voltage fields, 90VDC motors with 50VDC fields and 180VDC motors with 100VDC fields, connect field to terminals F1 and L1. See table 9 for summary of Field Connections. See figures 9A and 9B for field wiring diagrams.

CAUTION – Shunt-Wound motors may be damaged if field remains powered without motor rotating for an extended period of time.

TABLE 9 – FIELD CONNECTIONS (Shunt Wound Motors Only)

AC Line Voltage (VAC)	Motor Voltage	Field Voltage (VDC)	Field Connection
115	90	100	F+, F–
115	90	50	F+, L1
230	180	200	F+, F–
230	180	100	F+, L1
230	90*	100	F+, L1

*Step Down operation (see section II C, p. 7).

FIG. 9A – FULL VOLTAGE FIELD

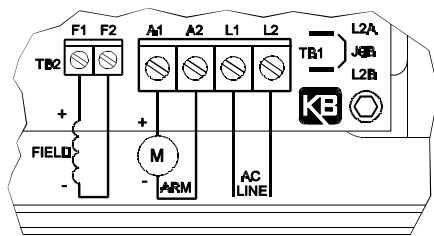
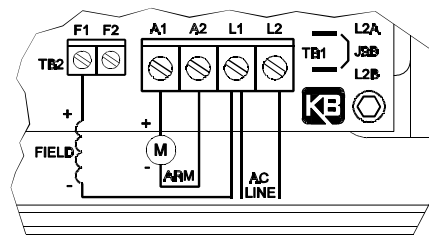

FIG. 9B – HALF VOLTAGE FIELD



D. Ground – Be sure to ground (earth) the control by connecting a ground wire to the Green Ground Screw located to the right of the terminal block. (See fig. 1, p. 3)

E. DC Tach-generator Input – If tach-generator feedback is required, an analog tach signal must be connected to the terminal block TB3. (Note: For tach-generator feedback Jumper J3 must be set to the "T" position, jumper J6 must be set for the proper tach voltage, and the IR COMP must be set to minimum (ccw) position.) (See section II F, p. 9.) Connect the tach-generator so that when the motor rotates the positive tach voltage lead is connected to T+ and the negative tach lead is connected to T– (See figure 10).

FIG. 10 – TACH-GENERATOR CONNECTION DIAGRAM

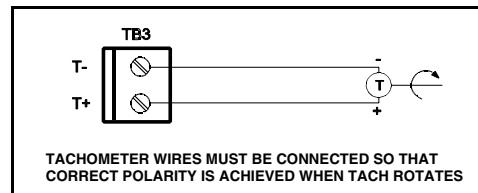

Note: If the tach voltage is connected backwards, the control will drive the motor at full speed only. Note: If the Forward-Brake-Reverse switch is used, provision must be made to reverse the polarity of the tach-generator leads when the control is switched to "Reverse."

Warning! To avoid erratic operation do not bundle AC Line and motor wires with potentiometer, voltage following, enable, inhibit or other signal wiring. Use shielded cables on all signal wiring over 12" (30 cm) – Do not ground shield.

F. Main Potentiometer – The control is supplied with the main potentiometer prewired. However, the control can also be operated from a remote potentiometer, or from an *Isolated* analog voltage for voltage following. To operate from an external source remove **white, orange and violet** potentiometer leads from terminals P1, P2 and P3. The leads may be taped and left in the control. The potentiometer itself may be removed, if a watertight seal is used to cover the hole in the front cover.

FIG. 11 – REMOTE POTENTIOMETER



1. Remote Potentiometer – Connect remote potentiometer wires to terminals P1, P2 and P3, so that the "high" side of the potentiometer connects to P3, the "wiper" to P2 and the "low" side to P1. (See figure 11.)

2. Analog Input – An isolated 0-5 or 0-10VDC analog voltage can also be used to drive the control. Note: If an isolated signal voltage is not available, an optional signal isolator can be installed (Model KBSI-240D, P/N 9431, see figure 17, p. 20 for signal isolator wiring diagrams). Connect the isolated input voltage to terminal P2 (+) and P1 (-). (See fig. 12)

FIG. 12 – ANALOG VOLTAGE

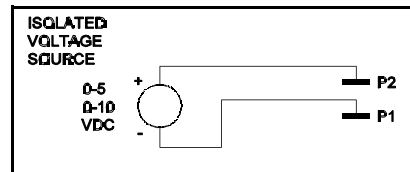

Note: Be sure jumper J7 corresponds to proper range of input voltage 0-10 or 0-5VDC. When the potentiometer is disconnected from P1, P2 and P3 to connect an analog input signal, the MIN trimpot will have to be adjusted clockwise to achieve a 0+ output voltage.

G. Remote Start/Stop Switch – A remote Start/Stop Switch can be installed by removing the wires from the "Start," "Com" and "Stop" terminals, and reconnecting them to a remote switch. (See fig. 13.) Note: To eliminate Start/Stop function, join the "Start" & "Com" Quick Connect terminals with a jumper.

FIG. 13 – REMOTE START/STOP SWITCH

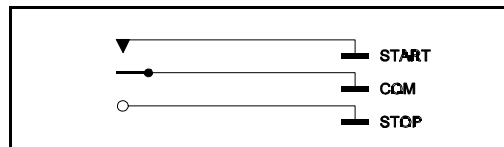

H. Inhibit – The control can be electronically stopped and started with the Inhibit circuit. To "Stop" the control, Terminals I1 & I2 must be joined via a contact. The control can be restarted by opening the contact.

FIG. 14 – INHIBIT CIRCUIT

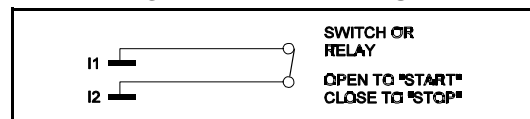

Note: The Inhibit should not be used as a safety disconnect. Use only the AC Line for that purpose. (See fig. 14.) Note: The Inhibit Circuit is not isolated. Do not common or ground inhibit leads.

I. Enable – The control can also be started and stopped with an Enable circuit (the Enable circuit functions opposite to that of the inhibit circuit; INHIBIT: open to start-close to stop, ENABLE: open to stop-close to start). The Enable function is established by wiring a contact in series with the violet potentiometer lead connected to terminal P3. (See fig. 15 on page 13.) The Enable circuit is not isolated. Do not common or ground wiring. **Note:** The MIN speed trimpot must not be set higher than 70% CW rotation (approx. 2:00 o'clock position) or Enable will not function.

FIG. 15 – ENABLE CIRCUIT

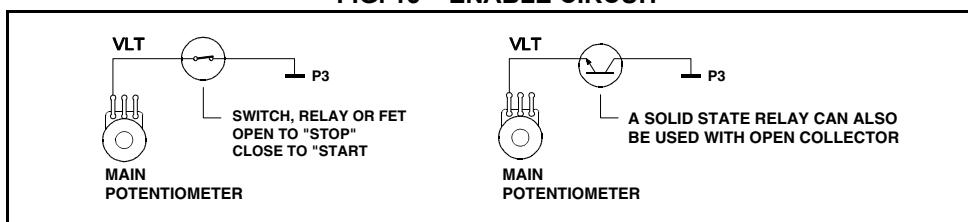

V. FUSING.

A. AC Line Fusing – Most electrical codes require that each ungrounded conductor contain fusing. Separate branch circuit fusing, or circuit breaker may be required. Check all electrical codes that may apply to the installation. This control does not contain AC line fuses. A 20 amp rated fuse or circuit breaker can be used.

B. Armature Fusing – The correct size armature fuse must be installed, depending on the rating of the motor. **Control will not operate if fuse is not installed.** Fuse type should be Littelfuse 326 ceramic, Buss ABC, or equivalent. A fuse chart is presented below which suggests appropriate armature fuse ratings. However, the specific application may require larger fuse ratings based on ambient temperature, CL set point and duty cycle of operation. (See table 10 below.) (Fuse rating is based upon 1.7 times the motor current rating.)

TABLE 10 – ARMATURE FUSE CHART

Motor Horsepower		Approx. DC Motor Current Amps	Fuse Rating (AC Amps)
90VDC	180VDC		
1/8	1/4	1.3	2
1/6	1/3	1.7	2
1/4	1/2	2.5	4
1/3	3/4	3.3	5
1/2	1	5.0	8
3/4	1	7.5	12
1	2	10.0	20

Note: Armature fuse is not supplied and must be installed for control to operate.

VI. OPERATION



WARNING! Read Safety Warning on page 2 before attempting to operate the control or severe injury or death can result. Failure to follow the Safety Warning Instructions may result in electric shock, fire or explosion.

After the control has been set up properly (the jumpers set to the desired positions, and the wiring completed), the start-up procedure can begin. If AC power has been properly brought to the control, the "ON" LED and the "STOP" LED indicators will be lighted. Before initially starting, be sure the main potentiometer is in the minimum position. To start the control move the Start/Stop toggle to the "Start" position and release. The "Stop" LED should extinguish and the motor should rotate as the potentiometer knob is rotated clockwise. Note: If the motor rotates in the incorrect direction, it will be necessary to disconnect the main AC power and reverse the armature wires. To stop the motor, move the Start/Stop toggle to the Stop position. If power is lost, the control will not restart, unless the Start/Stop toggle is moved to the Start position.

VII. TRIMPOT ADJUSTMENTS.

The control contains trimpots, which have been factory adjusted for most applications. Figure 1 page 3 illustrates the location of the trimpots and their approximate adjustment positions. Some applications may require readjustment of the trimpots in order to tailor the control to exact requirements. (See table 2, p. 5 for range and factory setting of all trimpots.) Readjust trimpots as follows: **WARNING.** Do not adjust trimpots with main power on if possible. **If adjustments are made with power on, insulated adjustment tools must be used and safety glasses must be worn. High voltage exists in this control. Electrocution and/or fire can result if caution is not exercised. Safety warning must be read and understood before proceeding.**

- A. Minimum Speed (MIN)** – The MIN trimpot is used to set the minimum voltage of the drive. This sets the minimum speed of the motor. Adjust the MIN trimpot as follows:
1. Rotate Main Potentiometer to minimum speed position (full counterclockwise).
 2. Increase setting of MIN trimpot so that motor runs at desired minimum speed.
- B. Maximum Speed (MAX)** – The MAX trimpot is used to set the maximum voltage of the drive. Adjust the MAX trimpot as follows:
1. Rotate Main Potentiometer to maximum speed position (full clockwise).
 2. Adjust MAX trimpot setting to desired setting of motor speed.
- C. Acceleration (ACCEL)** – The ACCEL trimpot sets the amount of time it takes the control to reach full output. The trimpot is factory set to one (1) second. If more rapid acceleration is desired, rotate the trimpot counterclockwise. Note: Rapid ACCEL setting may cause the current limit circuit to activate which will extend the acceleration time. For a longer acceleration time, rotate ACCEL trimpot clockwise. 50% rotation represents approximately seven (7) seconds and full rotation is approximately fifteen (15) seconds.
- D. Deceleration (DECEL)** – The DECEL trimpot sets the amount of time it takes the control to go from full speed to minimum speed when rotating the main potentiometer CCW. The trimpot is factory set to one (1) second, and can be readjusted to full counterclockwise position for more rapid DECEL. Note: On high inertial loads, a rapid DECEL setting may cause the motor to coast to a stop slower than the DECEL setting. To increase deceleration time, rotate DECEL trimpot clockwise. 50% rotation represents approximately seven (7) seconds and full rotation is approximately fifteen (15) seconds. Note: The Decel circuit works when rotating the main speed pot in the CCW direction or when opening the P3 lead of the main pot or when placing the Start/Stop Switch Toggle to the Stop position. It does not operate when power is removed.
- E. Current Limit (CL)** – This trimpot is used to set the maximum amount of DC current that the motor can draw. The amount of DC current determines the amount of maximum motor torque in both the Speed Control Mode and Torque Mode. The CL trimpot is factory set at 150% of the current established by the jumper J4 selection. Also see section VIII C, on page 15). Readjust the CL trimpot as follows:
1. Turn CL trimpot to minimum (CCW) position. Be sure jumper J4 is in proper position approximately equal to the motor DC ampere rating.
 2. When jumper J1 is set to the Speed Control Mode the main potentiometer should be set at 50% rotation. When jumper J1 is set to the Torque Mode the main potentiometer should be set at 100% of full rotation.
 3. Wire in a DC ammeter in series with armature lead. Lock shaft of motor.
 4. Apply power. Rotate CL trimpot CW until desired CL setting is reached (factory setting is 1.5 times rated motor current).

CAUTION:

1. Adjusting the CL above 150% of motor rating can cause overheating and demagnetization of some PM motors. Consult motor manufacturer.

2. Do not leave the motor in a locked condition for more than a few seconds since armature damage may occur.

F. IR Compensation (IR) – The IR comp circuit is used to stabilize motor speed under varying loads. **(Note: If control is in Tach Feedback mode, the IR trimpot should be set to minimum - ccw.)** Readjust the IR trimpot as follows:

1. Run the motor at approximately 30-50% of rated speed under no load and measure actual speed;
2. Load the motor to rated current. Rotate IR trimpot so that the loaded speed is the same as the unloaded speed measured in 1.

Control is now compensated so that minimal speed change will occur over a wide range of motor load. (Note: Too much IR Comp will cause unstable [oscillatory] operation.)

G. Timed Current Limit (TCL) – Jumper J5 must be in the "TCL" position, in order for Timed Current Limit to be operational. This trimpot determines the approximate amount of time the drive will stay in Current Limit before trip out. The trimpot has an adjustment range of .5-15 seconds and is factory set for seven (7) seconds. The trimpot can be reset according to the desired trip time. Rotating the trimpot clockwise increases the trip time. This function provides motor overload protection. (See page 9, section II, E 1, "Application Note," for TCL operation.)

H. Jog Speed (JOG) – This trimpot is operational only when the optional RUN-STOP-JOG Switch is installed (KB P/N 9340). In the JOG position the JOG trimpot can be used to set the JOG speed.

VIII. FUNCTION INDICATOR LAMPS.

The control contains three function LED Indicator Lamps that reflect its operational status.

A. Power On Indicator (ON) – This lamp will glow GREEN when the AC line is connected to the control.

B. Stop Indicator (STOP) – This lamp will glow YELLOW when the control is placed in the STOP mode with the Start/Stop Switch.

C. Overload Indicator (CL) – When the motor is loaded to the current limit setpoint (CL setpoint is established by the setting of jumper J4 and the CL trimpot), this lamp will glow RED. If the control is allowed to stay in CL and then trips out in Timed Current Limit, the OL LED will remain lighted, until the control is restarted with the Start/Stop Switch. If the OL LED remains lighted during control operation, a fault condition may exist. Possible causes for this condition are as follows:

1. Motor is overloaded – Check motor amps with DC ammeter in series with armature. (If motor is shunt type, field may be open or not receiving proper voltage.)
2. Motor may be defective – Check motor for shorts or grounds.
3. The CL may be set too low – Check position of jumper J4 and CL trimpot.

NOTE: In some applications, especially those requiring the motor to cycle on and off or from one speed to another, the OL indicator may blink indicating a transient overload. This may be a normal condition for the application.

IX. OPTIONAL ACCESSORIES.

A. RUN-STOP-JOG Switch (P/N 9340) – This switch provides a momentary jog speed that can be used to "inch" a machine into position. It assembles easily to the control via quick connect terminals. A rubber switch seal is included in order to maintain watertight integrity.

B. Forward-Brake-Reverse Switch (P/N 9339) – This module provides a reversing function along with dynamic braking. A special hesitation switch is used along with an Inhibit function which minimizes arcing and plug-reversing. The installation is made simple with the use of quick-connect terminals. **Note: Signal Isolator (P/N 9431) cannot be installed with Forward-Brake-Reverse Switch.**

- C. **Signal Isolator (Model KBSI-240D, P/N 9431)** – Signal isolation is required when a remote nonisolated analog signal is to be used. Provision is made to install Model KBSI-240D on 4 bosses inside the front cover. The unit accepts a variety of voltage and current signals.

Note: Forward-Brake-Reverse Switch (P/N 9339) cannot be installed with Signal Isolator.

- D. **Auto/Manual Installation Kit (P/N 9377)** – This kit facilitates mounting of KBSI-240D Signal Isolator into KBPC-240D. Contains Auto/Man Switch and necessary wiring and hardware. (KBSI-240D, P/N 9431 purchased separately).
- E. **ON/OFF AC Line Switch (P/N 9341)** – This option is desirable if a positive AC Line disconnect is required. The switch can be installed in lieu of the Start/Stop Switch (which can be easily removed) or in place of the Run-Stop-Jog or the Forward-Brake Reverse Switch. Installation is made via quick-connect terminals.
- F. **RFI Filter (Model KBRF-200A, P/N 9945A)** – The KBRF-200A meets the requirements of CE directives pertaining to RFI filtering.
- G. **Electronic Forward-Brake-Reverse (APRM-PC P/N 9378)** – The APRM-PC provides electronic reversing with solid state dynamic braking. Plug reversing is eliminated with KB's patented APRM®. The Unit is supplied with a FWD-BRK-REV toggle switch; however, it can also be switched with an external switch or relay.

FIG. 17 – CONNECTION DIAGRAMS FOR KBPC-240D WITH KBSI-240D SIGNAL ISOLATOR

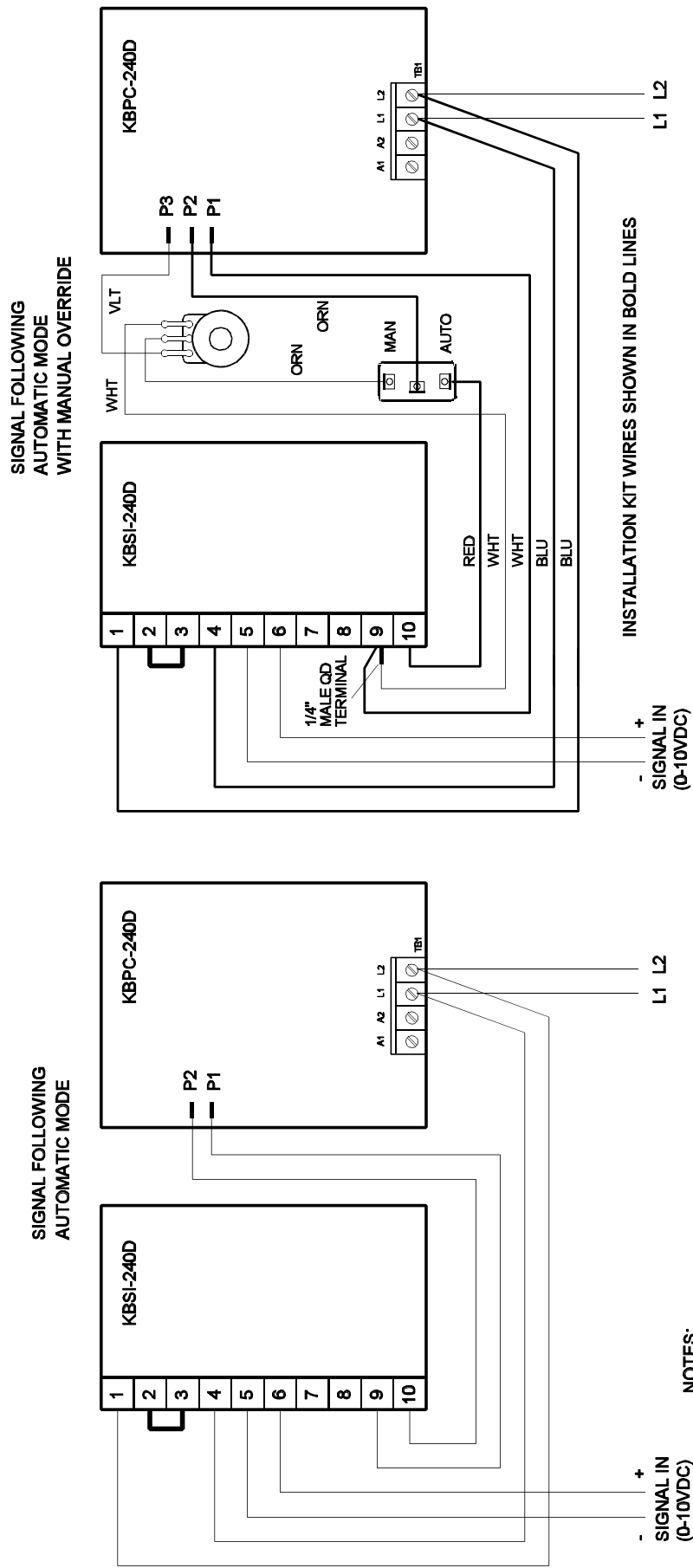

- NOTES:
1. KBSI-240D IS SHOWN WIRED FOR 230VAC LINE
 2. OTHER SIGNAL RANGES AVAILABLE. (SEE KBSI-240D INSTRUCTION MANUAL)

FIG. 18 – INTERNAL CONNECTION DIAGRAM

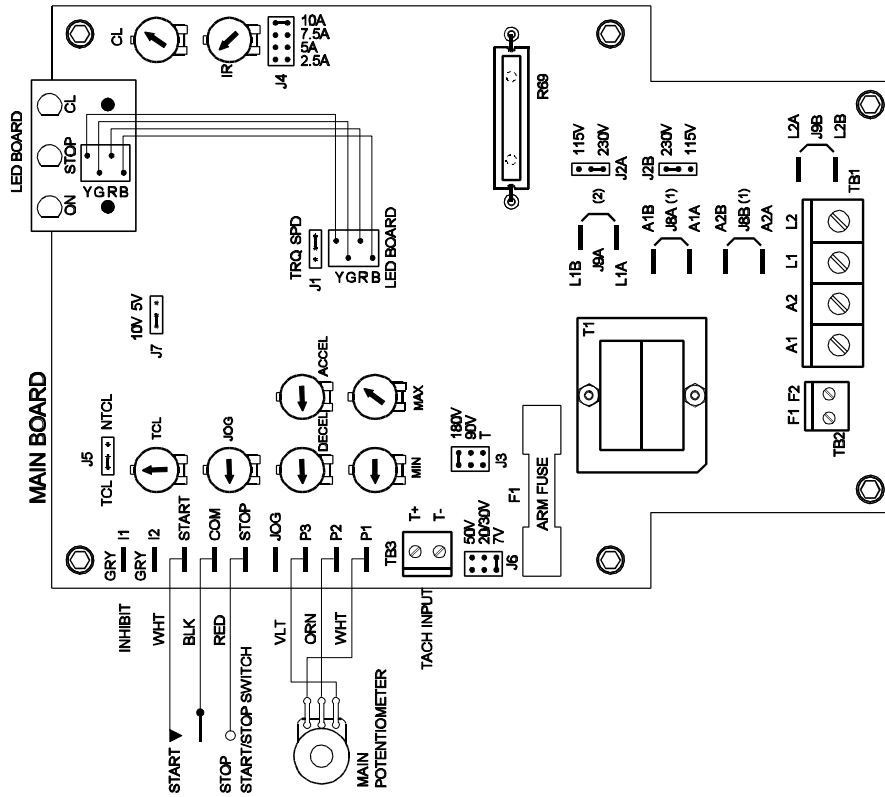

NOTES:

1. J8A AND J8B ARE REMOVED WHEN INSTALLING OPTIONAL FWD-BRK-REV SWITCH.
2. J8A AND J8B ARE REMOVED WHEN INSTALLING OPTIONAL ON/OFF AC LINE SWITCH.
3. START/STOP SWITCH IS REPLACED BY ON/OFF AC LINE SWITCH.
4. ALL JUMPERS ARE SHOWN IN FACTORY SET POSITIONS.

FIG. 19 – CONNECTION DIAGRAMS FOR AVAILABLE OPTIONS

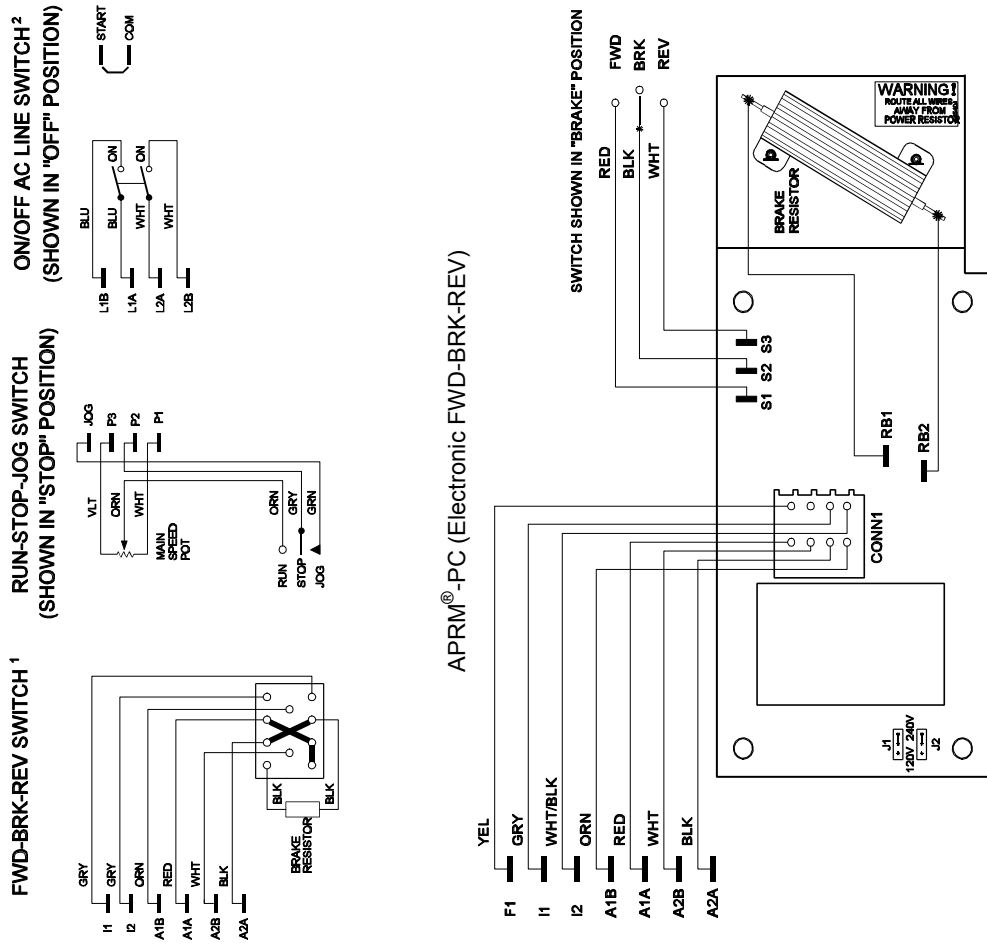

X – LIMITED WARRANTY

For a period of 18 months from date of original purchase, KB will repair or replace without charge devices which our examination proves to be defective in material or workmanship. This warranty is valid if the unit has not been tampered with by unauthorized persons, misused, abused, or improperly installed and has been used in accordance with the instructions and/or ratings supplied. The foregoing is in lieu of any other warranty or guarantee, expressed or implied, and we are not responsible for any expense, including installation and removal, inconvenience, or consequential damage, including injury to any person, caused by items of our manufacture or sale. Some states do not allow certain exclusions or limitations found in this warranty so that they may not apply to you. In any event, KB's total liability, under all circumstances, shall not exceed the full purchase price of this unit. (rev 4/88)



KB ELECTRONICS, INC.

12095 NW 39th Street, Coral Springs, FL 33065 • (954) 346-4900 • Fax (954) 346-3377
Outside Florida Call **TOLL FREE** (800) 221-6570 • **E-mail** – info@kbelectronics.com
www.kbelectronics.com

(A40400) – Rev. B – 3/98

INSTALLATION AND OPERATING INSTRUCTIONS

MODEL KBSI-240D

Signal Isolator KB Part No. 9431

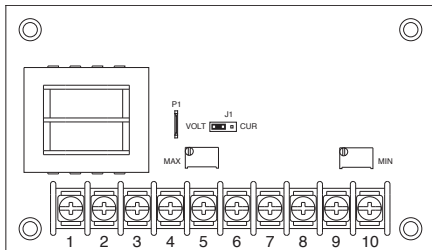

See Safety Warning on Page 1

The information contained in this manual is intended to be accurate. However, the Manufacturer retains the right to make changes in design which may not be included herein.

PENTA KB POWERTM

A COMPLETE LINE OF MOTOR DRIVES

© 2010 KB Electronics, Inc.

TABLE OF CONTENTS

Section	Page
i. Safety Warning	1
I. Introduction	2
II. Mounting	2
III. Wiring	5
IV. Output Signal	9
V. Limited Warranty	14

Tables

1. General Performance Specifications	4
2. Voltage Input Signal	7

Figures

1. Control Layout & Mechanical Specifications	3
2A. 115V Connection	5
2B. 230V Connection	5
3. Current Input Signal Connection	6
4. Voltage Input Signal Connections	7
5A. Leader/Multiple Follower Voltage Following System (Single Main Motor)	9
5B. Leader/Multiple Follower Voltage Following System (Single Main Potentiometer)	9
6A. Leader/Follower Voltage Following System	10
6B. Process Control with Auto/Manual Switch	10
6C. Process Control with Auto (Ratio Pot)/Manual Switch	11
6D. Auto/Manual Operation with Potentiometer on KBSI Input	11

i.   **SAFETY WARNING! Please read carefully:**

This product should be installed and serviced by a qualified technician, electrician, or electrical maintenance person familiar with its operation and the hazards involved. Proper installation, which includes electrical connections, mounting and adequate enclosure, fusing or other current protection, and grounding can reduce the chance of electrical shocks, and/or fires in this product or products used with this product, such as electric motors, switches, coils, solenoids, and/or relays. Do not use this drive in an explosion-proof application. Eye protection must be worn and insulated adjustment tools must be used when working with drive under power. This product is constructed of materials (plastics, metals, carbon, silicon, etc.) which may be a potential hazard. Proper shielding, grounding, and filtering of this product can reduce the emission of radio frequency interference (RFI) which may adversely affect sensitive electronic equipment. The input circuits of this drive may not be isolated from the AC line. Be sure to read and follow all instructions carefully. Fire and/or electrocution can result due to improper use of this product. The drive may contain electronic start/stop circuits, which are used for "Start" and "Stop" functions. However, these circuits are never to be used as safety disconnects since they are not fail-safe. Use only the AC line for this purpose. It is the responsibility of the equipment manufacturer and individual installer to supply this Safety Warning to the ultimate end user of this product. (SW 7/2009)

 This product complies with all CE directives pertinent at the time of manufacture. Contact factory for detailed installation instructions and Declaration of Conformity.

I. INTRODUCTION

The KBSI-240D Signal Isolator is used to isolate, amplify and condition DC voltage and current signals from any source (motors, tachs and transducers) which will drive most variable speed motor controls with a voltage following input. The maximum output voltage of the isolator is 10 volts, which is a linear function of the input signal.

The KBSI-240D is versatile since it can accommodate a wide range of input voltages (0 - 25*, 0 - 120 and 0 - 550V DC) and, in addition, a wide range of input current signals (4 - 20 mA, 10 - 50 mA and 1 - 5 mA). The Voltage/Current ("VLT/CUR") jumper is used to change the KBSI-240D from a voltage to current input.

A built-in power supply enables the KBSI-240D to be controlled with a 5K Ω remote potentiometer (connect potentiometer to terminals "P1," "5" and "6" – see page 9). The potentiometer can also be wired for Auto/Manual Operation.

**The input range of 0 - 25V is the maximum voltage that can be applied to terminals "5" and "6". The minimum input voltage is 0 - 5 volts, which can achieve an output voltage of 0 - 10 volts. The unit is factory calibrated so that a 0 - 10V DC input yields a 0 - 10V DC output.*

II. MOUNTING

Mount the Signal Isolator using (4) 6-32 screws (not included). Use the Control Layout and Mechanical Specifications drawing on page 3 to locate the mounting holes. The unit is designed to be mounted in any position providing its components do not come in contact with grounded or live wiring.

FIGURE 1 – CONTROL LAYOUT & MECHANICAL SPECIFICATIONS (INCHES / [mm])
 (Illustrates Factory Setting of Jumpers and Approximate Trimpot Settings)

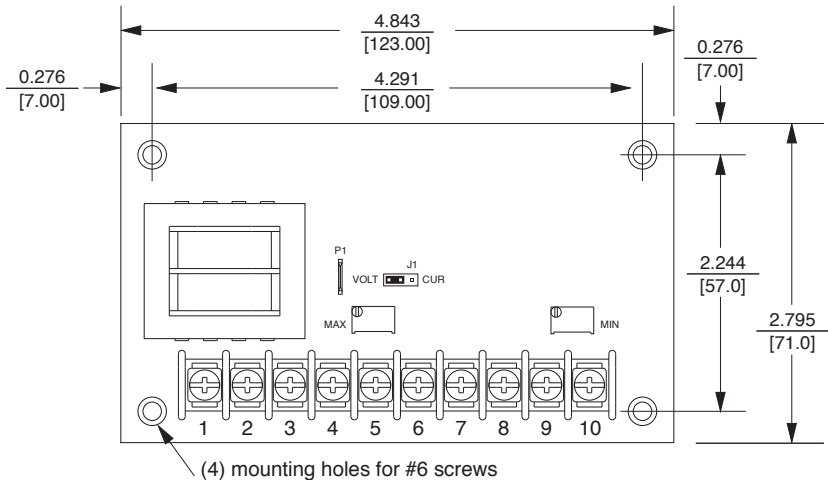

TABLE 1 – GENERAL PERFORMANCE SPECIFICATIONS

AC Power Requirements	115 or 208 - 230V AC, 50/60 Hz (1)
Signal Input Voltage (2)	0 - 25, 0 - 120, 0 - 550V DC
Signal Input Current (2)	1 - 5, 4 - 20, 10 - 50mA (3)
Maximum Output Voltage	10 Volts
Maximum Output Current	10mA
Range of "MIN" Trimpot	± 3 Volts
Range of "MAX" Trimpot	0 to 2 times the input voltage with maximum of 10 Volts
Linearity (4)	± 0.1%
Temperature Drift (4)	4 mV per °C
Operating Temperature Range	0 - 40 °C / 32 - 104 °F

Notes:

1. To achieve full specifications input voltage must be within ± 10% of nominal.
2. Floating (non-grounded) or grounded input signal may be used.
3. See Section III-B-i, on page 6.
4. Specifications are based on an output of 10 volts.

III. WIRING.



Warning! Read Safety Warning on page 1 before attempting to use this control.

Warning! To avoid erratic operation do not bundle AC Line and motor wires with potentiometer, voltage following, enable, inhibit or other signal wiring. Use shielded cables on all signal wiring over 12" (30 cm) – Earth ground the shield on the drive side only.

- A.** AC Power – The KBSI-240D is powered with either 115 or 230V AC, 50/60 Hz by arranging the jumpers between terminals “1” to “4” properly. See figures 2A and 2B. Be sure unit is wired in accordance with the National Electric Code and other codes that may apply. It is recommended that a 1 amp fuse be installed in series with the AC line.
- B.** Input Terminals – A voltage or current signal from a microprocessor, tachometer, transducer, etc. is to be connected to terminals “5” through “8.” The selection of the proper terminal is based on the maximum level of the input signal. See figures 3 and 4.

FIGURE 2A – 115V CONNECTION

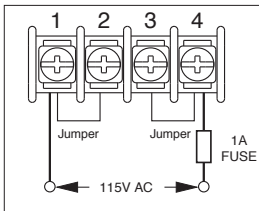
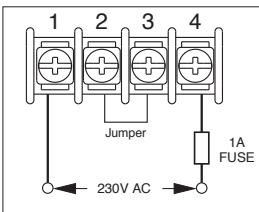

FIGURE 2B – 230V CONNECTION



i. Current Signal Input



Warning! Read Safety Warning on Page 1 before attempting to use this control.

The Signal Isolator accepts 4 – 20 mA DC input to provide 0 – 9 Volts DC output. Connect the current signal input common (–) to Terminal “5” and the positive (+) to Terminal “6”, as shown in Figure 3. Other current signal input ranges can also be used, as described below. Calibrate the Signal Isolator, as described below.

Note: Two resistors, for 10 – 50 mA and 1 – 5 mA inputs, are supplied in the hardware bag included with this kit.

4 – 20 DC Signal Input: No resistor required. Set Jumper J1 in “CUR” position.

10 – 50 mA DC Signal Input (Use Large Resistor with Color Code

“Brown–Green–Brown”): Install the 150Ω – 1W resistor across Terminals

“5” and “6”. Set Jumper J1 in “CUR” position.

1 – 5 mA DC Signal Input (Use Small Resistor with Color Code

“Brown–Black–Red”): Install the 1kΩ – 1/4W resistor across Terminals “5” and “6”. Set Jumper J1 in “VOLT” position.

Procedure to Calibrate the Signal Isolator When Using Current Signal Input:

1. Connect a DC voltmeter (a digital voltmeter is suggested) to Terminals “9” (–) and “10” (+).
2. Apply the minimum signal input current to Terminals “5” (–) and “6” (+).
3. Adjust the MIN Trimpot on the Signal Isolator to obtain an output voltage of 0 Volts DC.
4. Apply the maximum signal input current to Terminals “5” (–) and “6” (+).
5. Adjust the MAX Trimpot on the Signal Isolator to obtain an output voltage of 9 Volts DC.

Notes: 1. To achieve better accuracy, repeat steps 2 – 5. **2.** If other than 0 Volts DC (minimum) and 9 Volts DC (maximum) is desired, use the MIN and MAX Trimpots on the Signal Isolator to adjust the

6 output to the desired voltages in steps 3 and 5.

**FIGURE 3
CURRENT SIGNAL
INPUT CONNECTION**

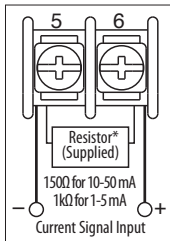

*No resistor required for 4-20 mA.

ii. Voltage Input Signal



Warning! Read Safety Warning on Page 1 before attempting to use this control.

Note: The Voltage/Current (VLT/CUR) jumper must be in the VLT position (factory setting). The KBSI-240D is designed to accept a wide range of input voltage signals as follows:

TABLE 2 – VOLTAGE INPUT SIGNAL

Input Terminals	Minimum Input Voltage Range	Maximum Input Voltage Range
5, 6	0 - 5	0 - 25
5, 7	0 - 25	0 - 120
5, 8	0 - 120	0 - 550

Connect input voltage signal to proper input terminals as indicated in figure 4.

1. Connect a 10V DC meter (digital meter is suggested) to terminals “9” (-) and “10” (+).
2. Apply the maximum input voltage that would be supplied from tach, transducer, etc.
3. Adjust the “MAX” trimpot to the desired output voltage.

Example: A follower motor is to follow the output of a main motor with an armature voltage range of 0 - 90V.

FIGURE 4 – VOLTAGE INPUT SIGNAL CONNECTIONS

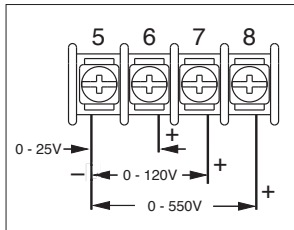

- a) Connect the armature of the main motor to the SI input terminals “5” (-) and “7” (+).
- b) Set the armature voltage of the main motor to zero (0). Adjust the “MIN” trimpot so that the output at terminals “9” and “10” reads zero (0) volts.
- c) Reset the armature voltage of the main motor to 90V. Adjust the “MAX” trimpot so that the output voltage is 9V DC.

Notes:

1. When setting the output voltage using the “MIN” and “MAX” trimpots the voltage or speed of the driven motor can be read directly instead of using the output of the KBSI.
2. When readjusting the “MIN” and “MAX” trimpots, always set the minimum voltage first and then the maximum voltage.
3. Trimpots allow approximately 20 turns for the full range of adjustment. If during the adjustment procedure the output stops changing, try reversing the direction of rotation of trimpot.

IV. OUTPUT SIGNAL

The output signal from the SI is obtained from terminals “9” (-) and “10” (+). Connect the output directly to the signal following input terminal of the speed control. For multiple follower motors, several controls can be driven from a single KBSI-240D. Be sure the AC line connections to the follower control are to the same phase (eg, L1 to L1 and L2 to L2 of all controls.)

The output from the KBSI-240D can be scaled to control the speed control over any desired speed range. Adjust the “MIN” trimpot to provide the desired minimum speed and the “MAX” trimpot to provide the desired maximum speed.

FIGURE 5 – LEADER/MULTIPLE FOLLOWER VOLTAGE FOLLOWING SYSTEM

A) From a Single Main Motor

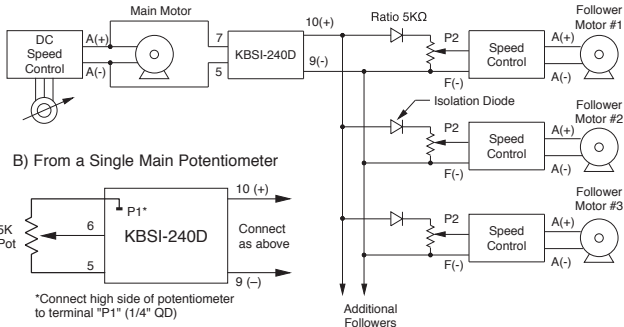

A 10K ratio potentiometer is used to control up to ten (10) follower motors.

If a 5K ratio potentiometer is used, up to five (5) follower motors can be controlled.

B) From a Single Main Potentiometer

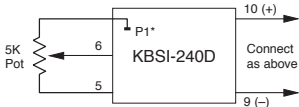

*Connect high side of potentiometer to terminal "P1" (1/4" QD)

WARNING! If Signal Isolator is connected to multiple speed controls;

- 1) Multiple controls must be powered from the same phase of AC line.
- 2) The positive input terminal to each speed control must be installed with a 1 amp, 600V (1N4005) isolation diode as shown.
- 3) Multiple speed controls can not be used with PWM, Regenerative or Variable Frequency Drives (Inverters).

FIGURE 6A – LEADER/FOLLOWER VOLTAGE FOLLOWING SYSTEM

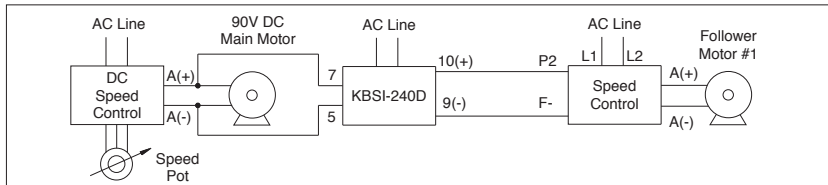

FIGURE 6B – PROCESS CONTROL WITH AUTO/MANUAL SWITCH

The KBSI-240D can be wired in an Auto/Manual mode which will allow manual override of an automatic process. See figure 6B.

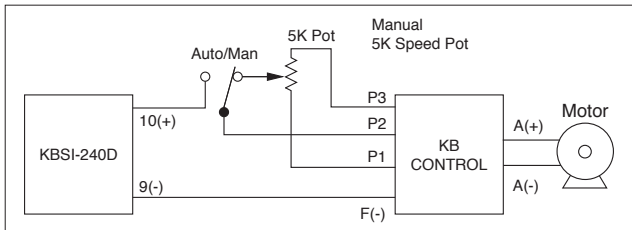

FIGURE 6C – PROCESS CONTROL WITH AUTO (RATIO POT)/MANUAL SWITCH

The following circuit provides for dual purpose usage of the speed pot. In the "AUTO" mode it is used for ratio control and in the "MAN" mode it is used for manual speed adjustment.

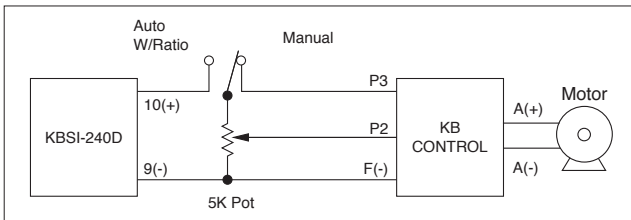
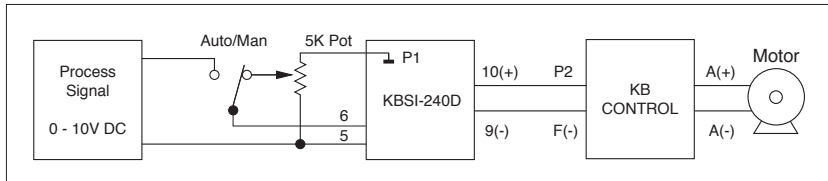

FIGURE 6D – AUTO/MANUAL OPERATION WITH POTENTIOMETER ON KBSI INPUT



Note: The preceding circuit provides for the speed pot to be used in "MAN" mode only. In "AUTO" mode, the process control signal is supplied directly to the signal isolator.

- NOTES -

- NOTES -

V. LIMITED WARRANTY

For a period of 18 months from the date of original purchase, KB Electronics, Inc. will repair or replace, without charge, devices which our examination proves to be defective in material or workmanship. This warranty is valid if the unit has not been tampered with by unauthorized persons, misused, abused, or improperly installed and has been used in accordance with the instructions and/or ratings supplied. The foregoing is in lieu of any other warranty or guarantee, expressed or implied. KB Electronics, Inc. is not responsible for any expense, including installation and removal, inconvenience, or consequential damage, including injury to any person, caused by items of our manufacture or sale. Some states do not allow certain exclusions or limitations found in this warranty and therefore they may not apply to you. In any event, the total liability of KB Electronics, Inc., under any circumstance, shall not exceed the full purchase price of this product.

(Rev 2/2000)



KB Electronics, Inc.

12095 NW 39th Street, Coral Springs, FL 33065-2516 • (954) 346-4900 • Fax (954) 346-3377
Outside Florida Call TOLL FREE (800) 221-6570 • email – info@kbelectronics.com
www.kbelectronics.com

(A40255) – Rev. E – 9/7/2010

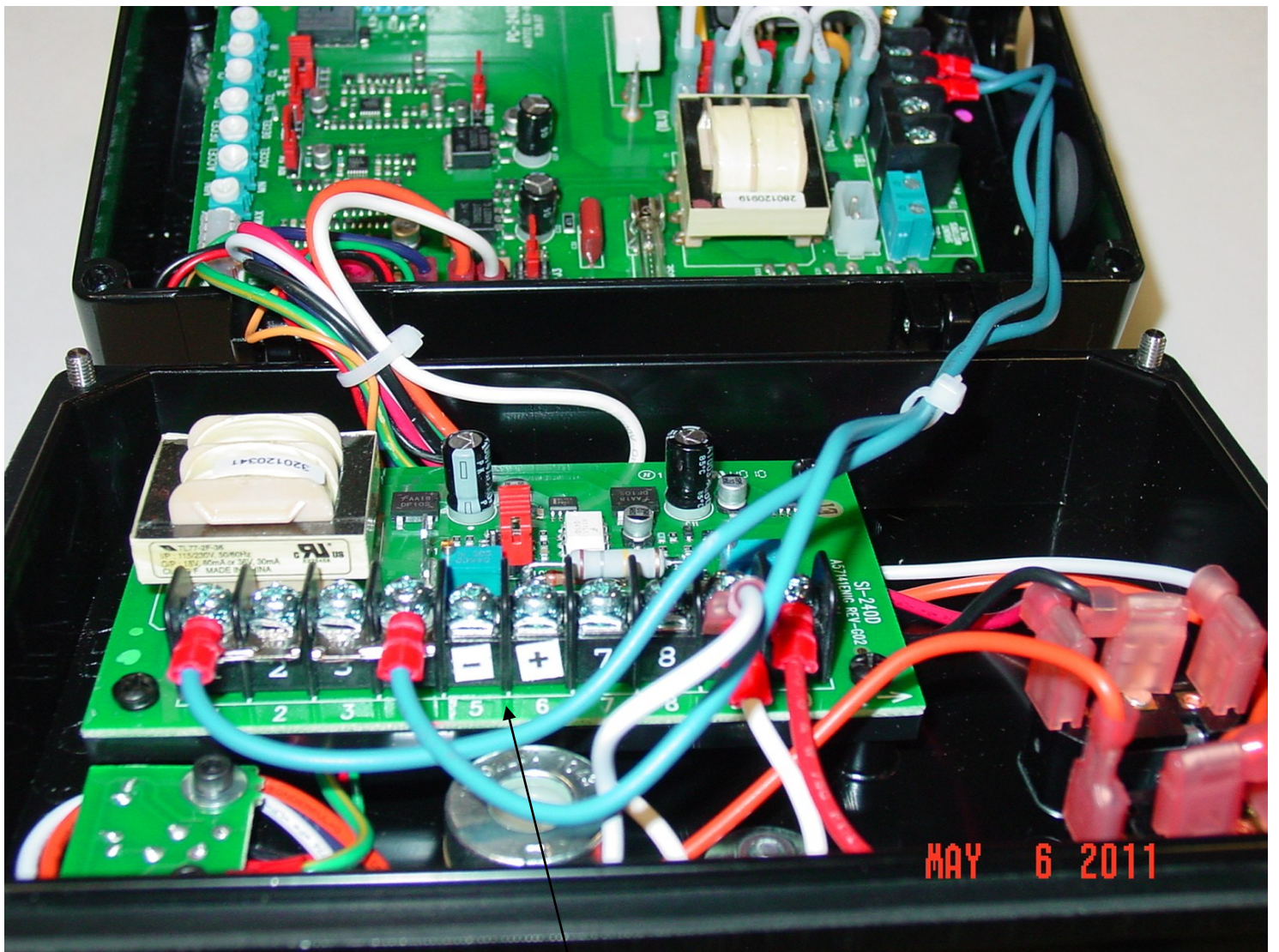

4-20 MA SIGNAL INPUT

The 4-20 ma signal for remote speed control is connected to terminals #5 (negative) and #6 (positive). This terminal strip is on the back of the front cover to the Penta Drive controller.